

Splines

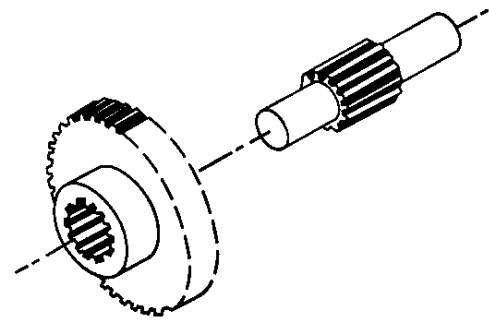

(a) General form of spline connection

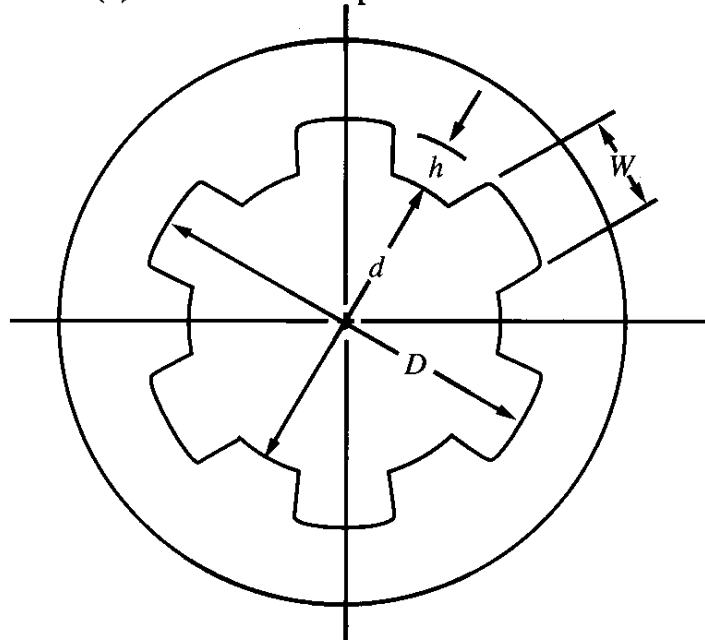

(b) Internal spline

- Splines can be thought of as a series of axial keyways with mating keys machined onto a shaft.
- There are two major types of splines used in industry: 1) straight-sided splines, and 2) involute splines.
- Splines provide a more uniform circumferential transfer of torque to the shaft than a key.

Splined Shaft and Hub

External Spline



Internal Spline

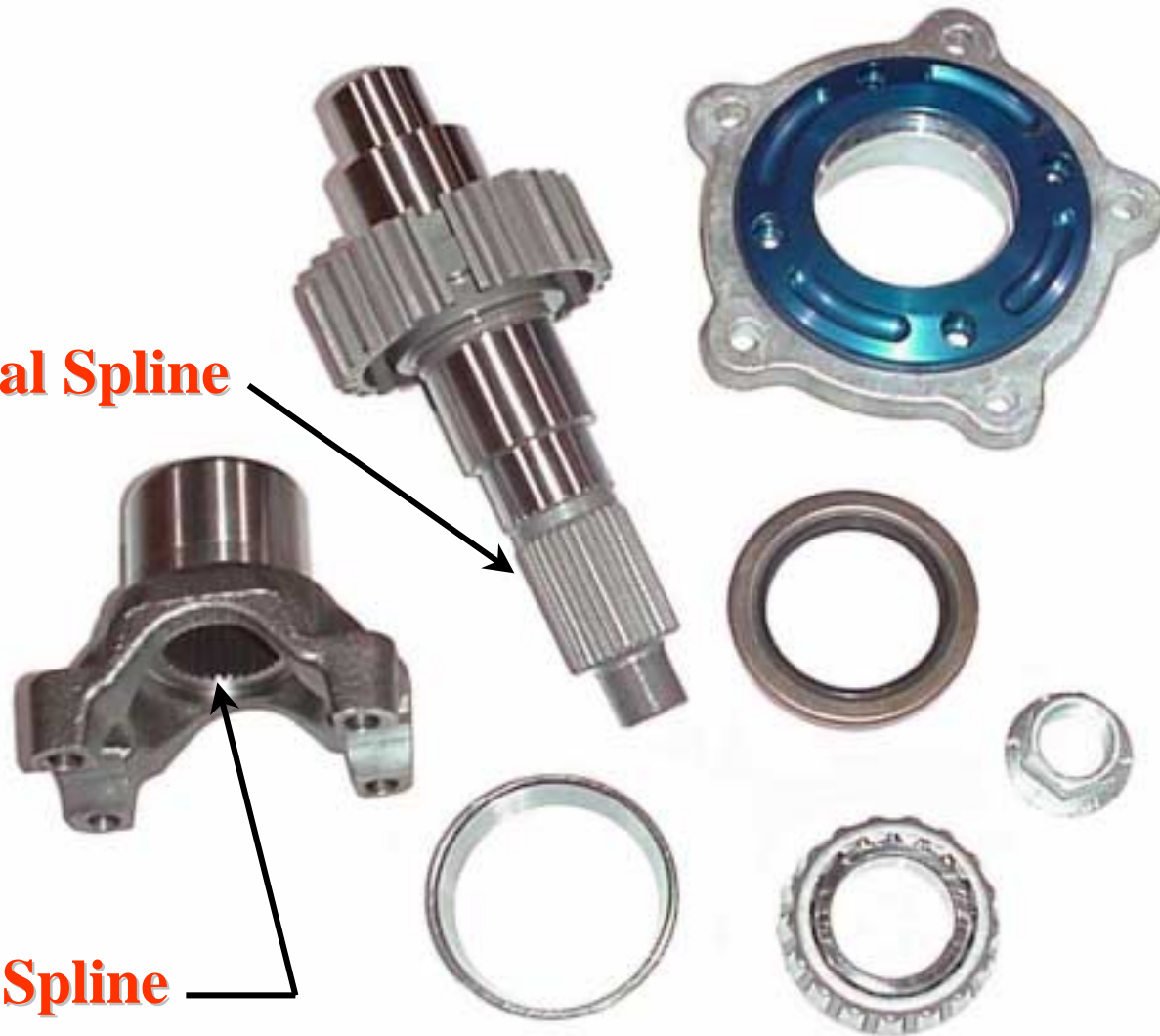

Spline Standards

- ❑ ANSI B92.1-1970 (R1982), Involute Splines, American National Standards Institute.
- ❑ ANSI B92.2-1980, Metric Module Involute Splines, American National Standards Institute.
- ❑ SAE Straight Tooth Splines

Straight-Tooth Spline Geometry

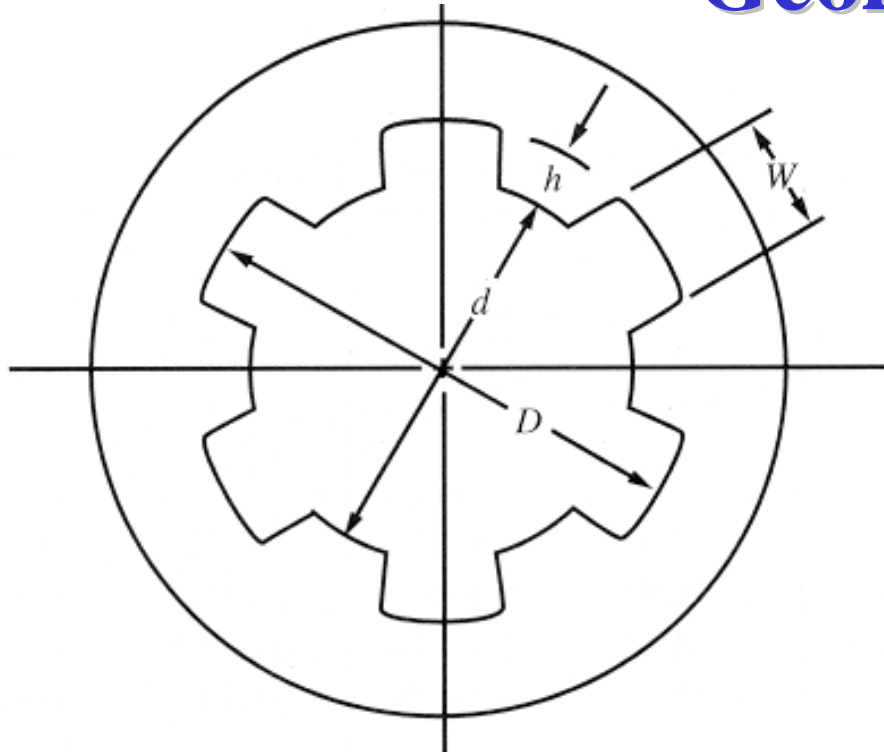

- SAE straight-tooth splines usually contain 4, 6, 10, or 16 splines.
- Parameter dimensions are controlled by the fit needed for a particular application.

No. of splines	W , for all fits	A: Permanent fit		B: To slide without load		C: To slide under load	
		h	d	h	d	h	d
Four	0.241D	0.075D	0.850D	0.125D	0.750D		
Six	0.250D	0.050D	0.900D	0.075D	0.850D	0.100D	0.800D
Ten	0.156D	0.045D	0.910D	0.070D	0.860D	0.095D	0.810D
Sixteen	0.098D	0.045D	0.910D	0.070D	0.860D	0.095D	0.810D

Mott, Fig. 11-4

Straight-Tooth Spline Strength

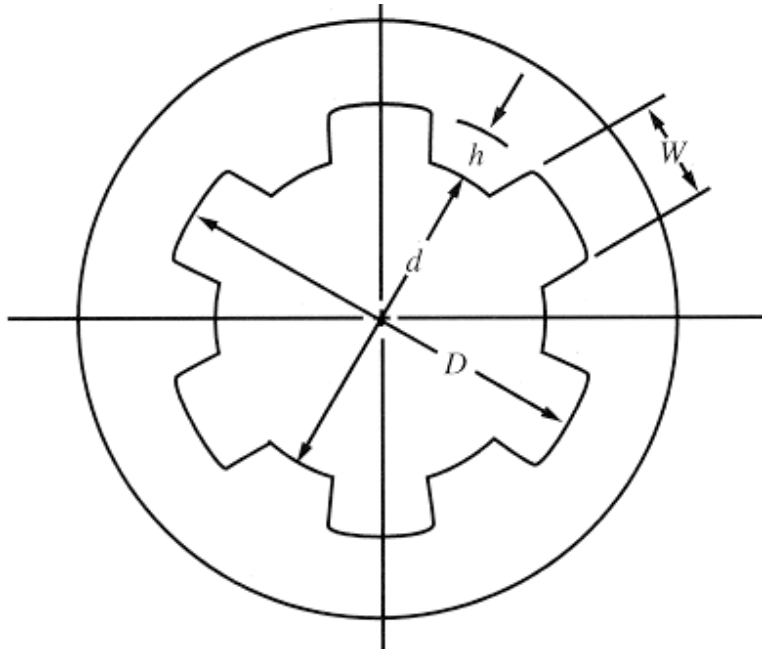

- The torque capacity per unit length of an SAE spline is based on a 1,000 psi bearing stress on the sides.
- Depending on the class of fit, a spline is able to accommodate axial movement along the shaft and still transmit torque.

Splines have the same failure mechanisms as keys:
1) shear or 2) bearing.

Straight-Tooth Spline Strength

(Continued)

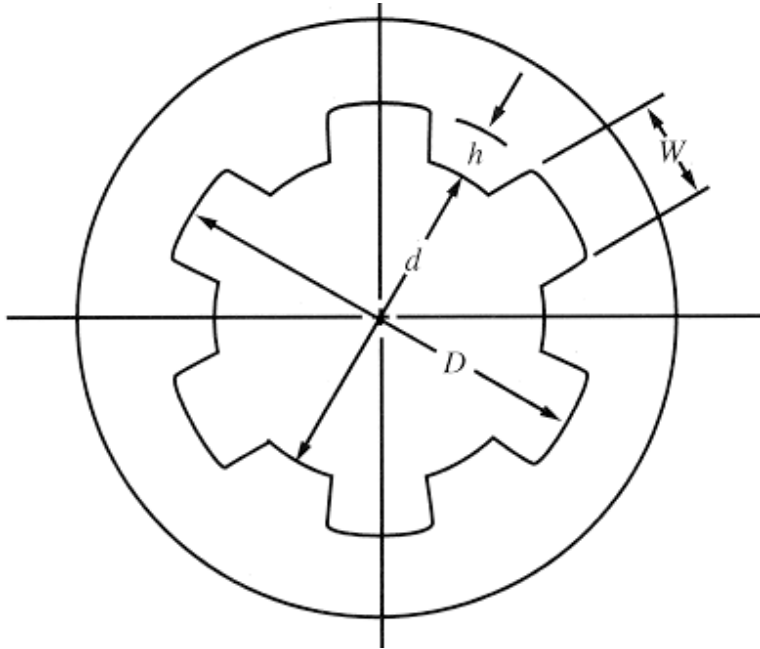

T = Torque per unit length
 N = Number of teeth
 D = Major spline diameter
 d = Minor spline diameter
 $d = f(D)$

$$T = 1,000 \cdot N \cdot R \cdot h$$

$$R = \frac{1}{2} \left(\frac{D}{2} + \frac{d}{2} \right) = \frac{D+d}{4}$$

$$h = \frac{1}{2}(D-d)$$

$$T = 1,000 \cdot N \cdot \frac{D+d}{4} \cdot \frac{1}{2}(D-d)$$

$$T = 1,000 \cdot N \cdot \left(\frac{D^2 - d^2}{8} \right)$$

Torque Capacity Curves (SAE Straight-Tooth Splines)

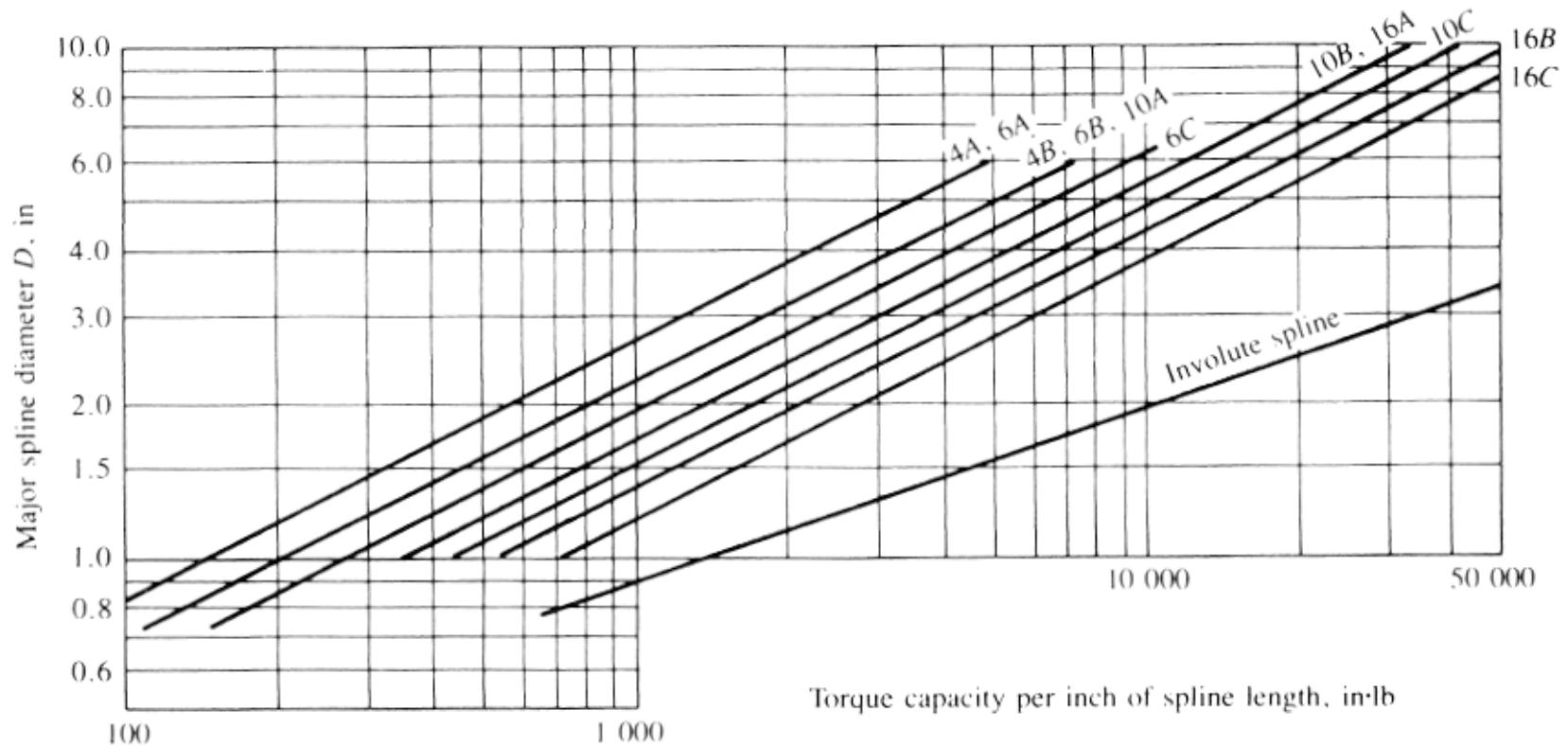

Note that an involute spline has a higher torque capacity than does a straight-tooth spline of the same major diameter.

Involute Splines

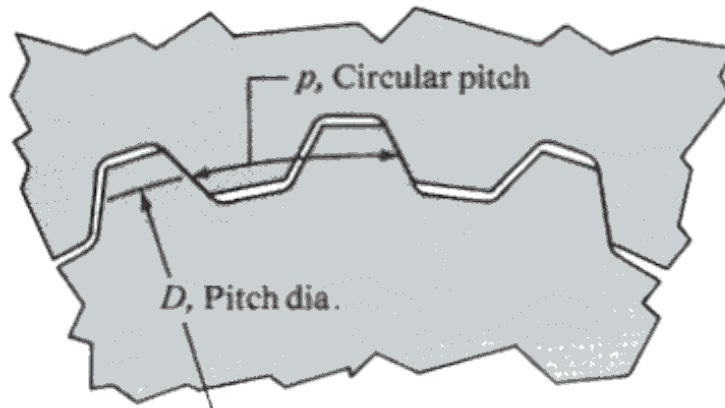

(a) Side-fit spline

N = Number of spline teeth
 P = Diametral pitch
 $D = N/P =$ Pitch dia.
 $p = \pi/P =$ Circular pitch

Minor dia.:

Internal: $\frac{N-1}{P}$

External: $\frac{N-1.35}{P}$

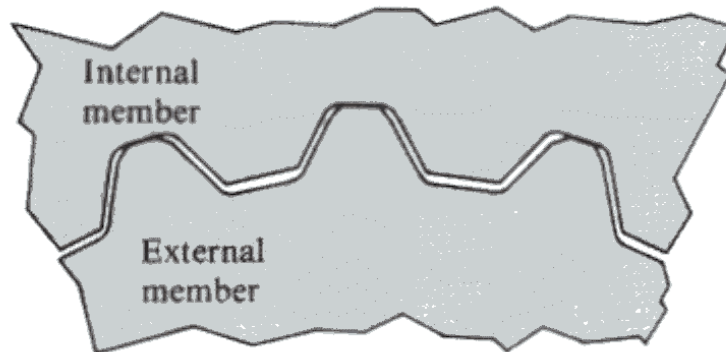

Note chamfer on tips of external spline teeth

(b) Major dia. fit spline

Major dia.:

Internal: $\frac{N+1.35}{P}$ side fit

$\frac{N+1}{P}$ major dia. fit

External: $\frac{N+1}{P}$

Involute splines generally have a 30° pressure angle.

Standard Diametral Pitches and Lengths

Diametral Pitches

There are seventeen diametral pitches in common use:

2.5	3	4	5	6	8	10
12	16	20	24	32	40	48
64	80	128				

Standard Lengths

Common designs use spline lengths of $0.75 D$ to $1.25 D$, where D is the pitch diameter of the spline. When these standard lengths are used, the shear strength of the splines will exceed that of the shaft from which they are made.

Spline Manufacturing Methods

Splines are either “cut” (machined) or rolled. Rolled splines are stronger than cut splines due to the cold working of the metal. Nitriding is common to achieve very hard surfaces which reduce wear.

Rolled Spline Process



Forged blank is rolled under tons of pressure prior to heat treating.



The finished spline is more accurate and stronger (35%) than cut splines.

Spline Failure Example



Note the yielding of the shaft outside of the engagement area due to a torsional load. The mating internal spline forced the external splines to remain parallel. In this case the spline is stronger than the shaft.

Splined Linear Bearing

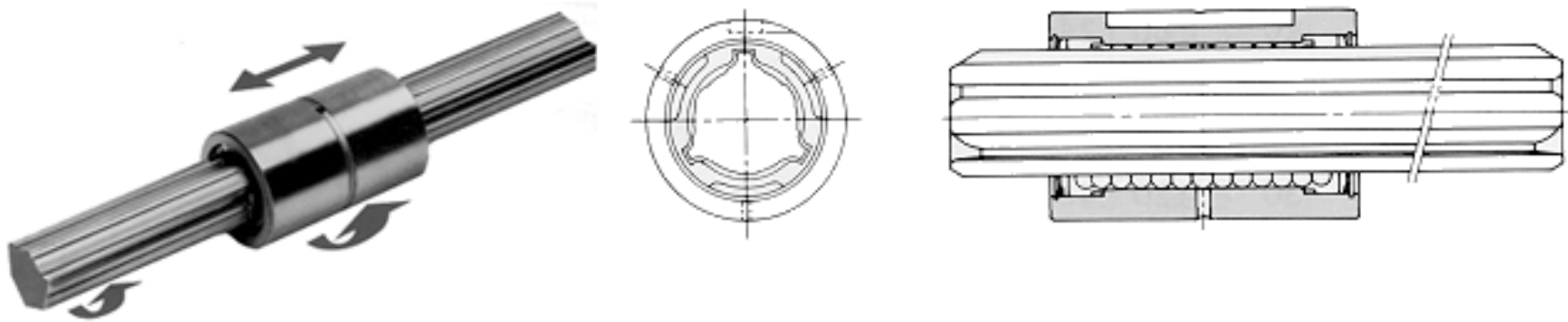

Circular shaped splines have been combined with ball bearings to create linear bearings that can resist a torsional load.

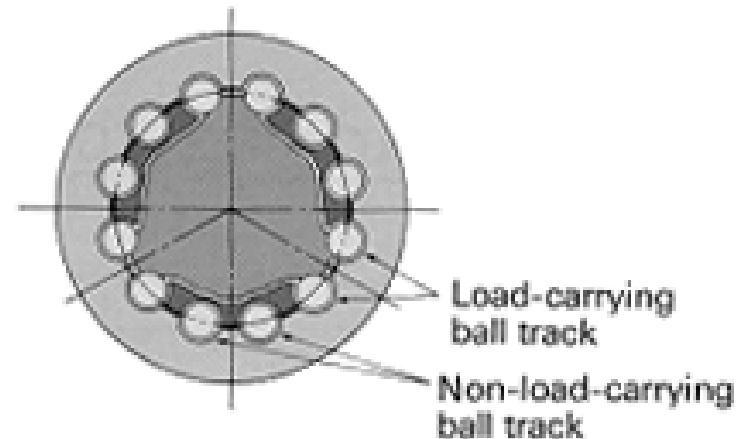

Polygons

An alternative to splines that has significantly lower stress concentration is the polygon. Four and three lobed polygons are shown.



Design information on polygons is available from General Polygon.

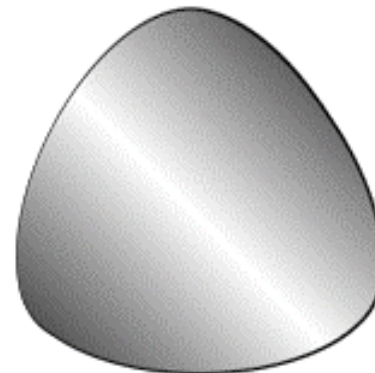
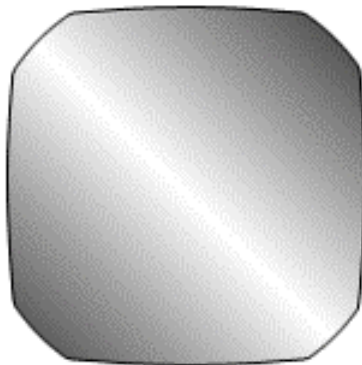





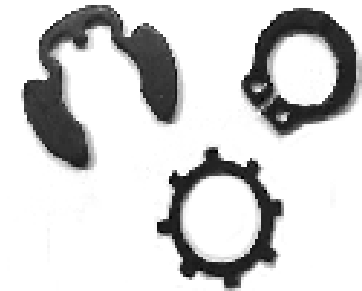
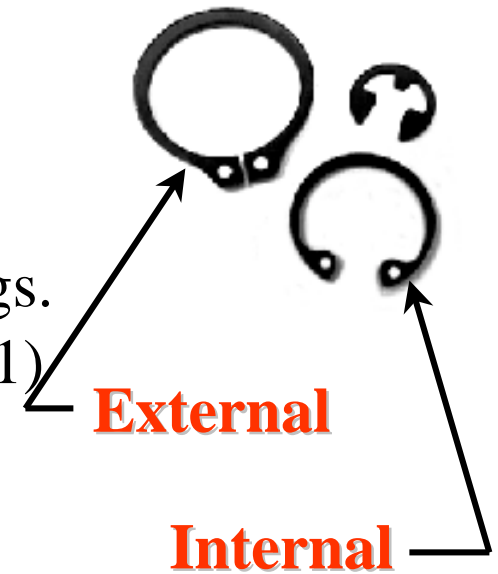



















Retaining Rings

- ❑ Retaining rings are used on shafts to maintain the axial position of components.
- ❑ There are many types of retaining rings. In general, they may be classified as: 1) internal and 2) external.



Different Types of Retaining Rings

 <p>EXTERNAL RETAINING RING DIN 471</p>	 <p>INTERNAL RETAINING RING DIN 472</p>	 <p>EXTERNAL E-CLIP DIN 6799</p>	 <p>TYPE AV EXTERNAL V-RING</p>	 <p>TYPE JV INTERNAL V-RING</p>
 <p>TYPE NT-0, MS-0 BEVELED EXTERNAL RETAINING RING</p>	 <p>TYPE MT BEVELED INTERNAL RETAINING RING</p>	 <p>TYPE BETW-0 BOWED EXTERNAL E-CLIP</p>	 <p>EXTERNAL RETAINING RING HEAVY SERIES DIN 471</p>	 <p>INTERNAL RETAINING RING HEAVY SERIES DIN 472</p>
 <p>EXTERNAL K-RING DIN 983</p>	 <p>INTERNAL K-RING DIN 984</p>	 <p>TYPE H CRESCENT RINGS</p>	 <p>TYPE S INTERLOCKING RINGS</p>	 <p>TYPE G GRIP RINGS</p>
 <p>TYPE AW BOWED EXTERNAL W-RING</p>	 <p>TYPE JW BOWED INTERNAL W-RING</p>	 <p>TYPE ST CIRCLIPS</p>	 <p>TYPE K-O CIRCLIPS</p>	 <p>TYPE UTW-O CIRCLIPS</p>
 <p>TYPE AL EXTERNAL L-RING</p>	 <p>TYPE JL INTERNAL L-RING</p>	 <p>TYPE SL CIRCLIPS</p>	 <p>FLAT WIRE CIRCLIPS DIN 5417</p>	 <p>PISTON PIN CIRCLIPS DIN 73130/73123</p>

Spring Loaded Retaining Rings

- ❑ “Bowed” retaining rings provide restoring forces to the components being held.
- ❑ Flat retaining rings allow small amounts of axial motion of the held component.



Bowed Internal Retaining Ring



Bowed External Retaining Ring

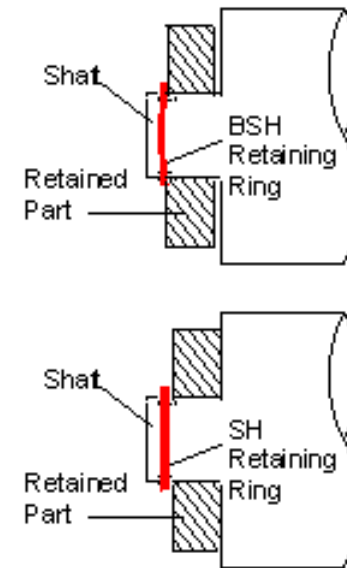

Smalley Compression Spring Retaining System



Higher restoring forces can be obtained using compression rings manufactured by Smalley.

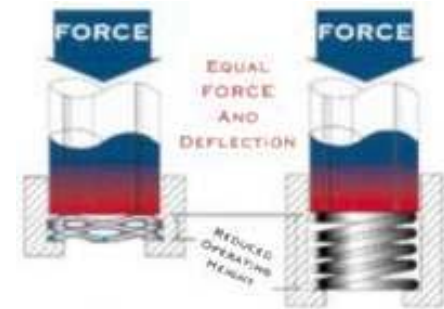

Retaining Ring Stress Concentrations

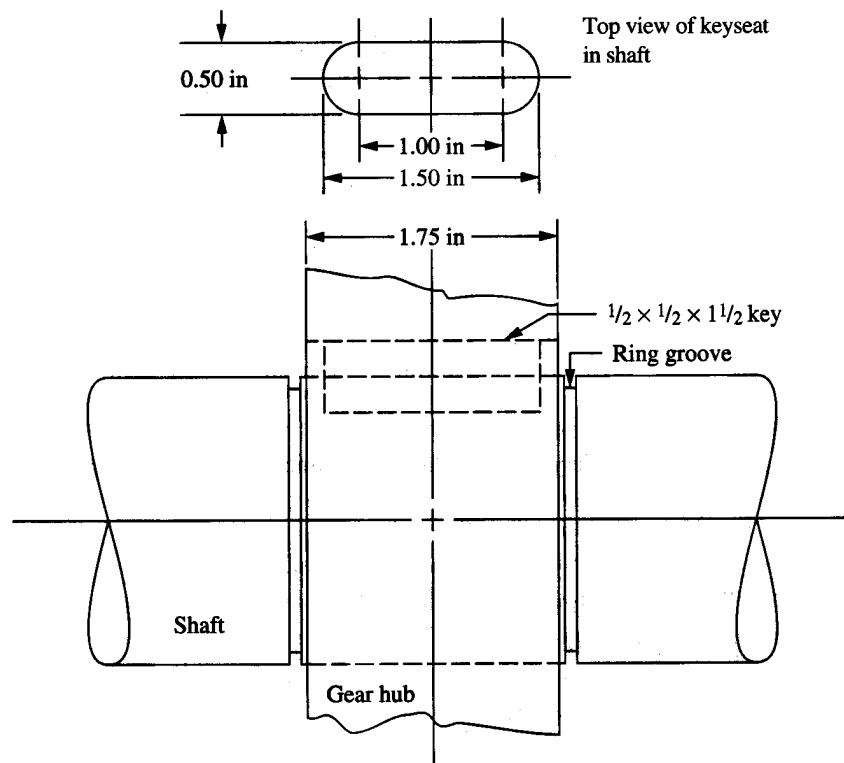

- External retaining rings used on shafts require that grooves be cut into the shaft.
- The grooves generally have sharp corners or very small fillet radii which result in significant stress concentration factors.

Retaining Ring Stress Concentration Factors

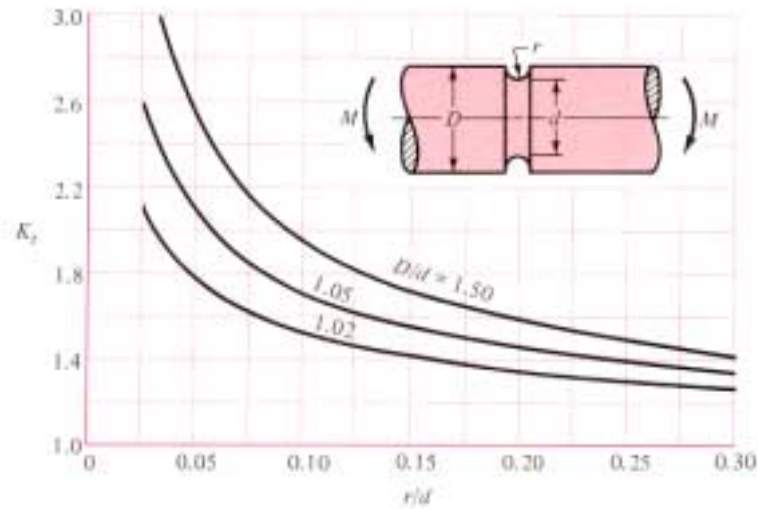

□ The high stresses at the root of the retaining ring groove will be highly localized and will not significantly effect the static strength of a shaft made from a ductile material.

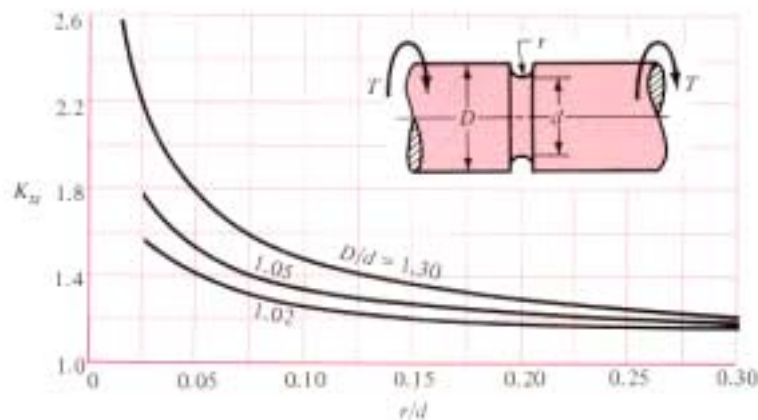

□ The stress concentration factors will be important in determining the life of the shaft and must be included in life calculations.

Retaining Ring Design

Dimensions and design guidelines for retaining rings are contained in catalogs and literature published by retaining ring manufacturers.

Rotoclip, Inc.

Smalley

Waldes Truarc, Inc.

Designs that use retaining rings must take into account how the rings will be installed and make sure that sufficient assembly clearance is provided.

Integral Shafts



- ❑ An alternative to attaching components to shafts is to machine the components directly onto the shaft.
- ❑ This higher priced approach is often the only approach available when tight space constraints exist.
- ❑ Complex combinations of components can be obtained using modern CNC turning centers. www.astas.co.za/shafts.html

Assignment

- 1) Make a drawing of an SAE straight-tooth- 4-spline connection having a major diameter of 1.5000 in and a class A fit. Show all critical dimensions. What is the torque capacity of the spline?
- 2) Identify two applications of retaining rings used in mechanical equipment. Describe the applications and discuss why you think retaining rings of the type used were chosen by the designer.